

Manual Accessories

Bolt Retainers –

- For use with clamps featuring U-bar and open bar clamping arms

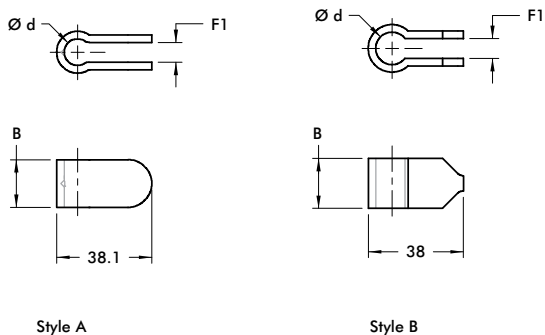

Part No.	A	B	Ød	F1	For Spindle Diameter	Style
▲ 207105	[1.25] 31,8	[0.63] 16	[0.33] 8,4	[0.25] 6,4	M8 or 5/16	A
■ 207105-M	[1.26] 32		[0.32] 8,2	[0.24] 6		B
▲ 210114	[1.50] 38,1	[0.75] 19,1	[0.53] 13,5	[0.31] 8	M10 or 3/8	A
■ 210114-M	[1.49] 38	[0.78] 20	[0.51] 13			B
▲ 247110	[1.63] 41,4	[0.88] 22,3	[0.56] 14,2	[0.38] 9,7	M12 or 1/2	A
■ 247110-M	[1.61] 41	[0.87] 22,2	[0.57] 14,4			B
● 110122	[1.88] 47,8	[1.25] 31,8	[0.64] 16,3		M16 or 5/8	A
▲ 250121		[1.00] 25,4			M12 or 1/2	
● 2002115-E	[0.97] 24,6	[0.50] 12,7	[0.26] 6,6	[0.23] 5,8	M6 or 1/4	
● 2007115-E	[1.26] 32	[0.75] 19,1	[0.34] 8,6		M8 or 5/16	B
● 2010115-E	[1.58] 40,1	[1.13] 28,7	[0.41] 10,4	[0.32] 8,1	M10 or 3/8	

Flanged Washers –

- For use with clamps featuring U-bar and open bar clamping arms
- Zinc plated

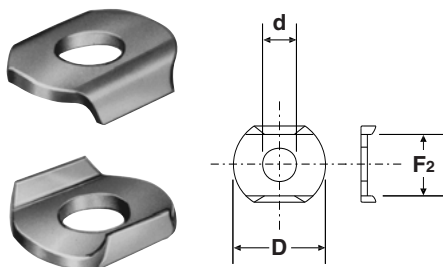

Part No.	ØD	Ød	F2	For Spindle Diameter
● 105106	[0.44] 11,2	[0.17] 4,3	[0.33] 8,3	M4 or #8
● 102111	[0.56] 14,2	[0.20] 5,1	[0.38] 9,6	M5 or #10
● 215105	[0.69] 17,5	[0.26] 6,7	[0.50] 12,7	M6 or 1/4
● 507107	[0.88] 22,4	[0.33] 8,4	[0.59] 15	M8 or 5/16
● 235106	[1.00] 25,4	[0.41] 10,5	[0.75] 19,1	M10 or 3/8
● 247109	[1.26] 32	[0.53] 13,5	[0.91] 23,2	M12 or 1/2
● 267102	[1.44] 36,5	[0.66] 16,8	[1.03] 26,2	M16 or 5/8

Flanged Washers-Stainless Steel

- For use with clamps featuring U-bar and open bar clamping arms

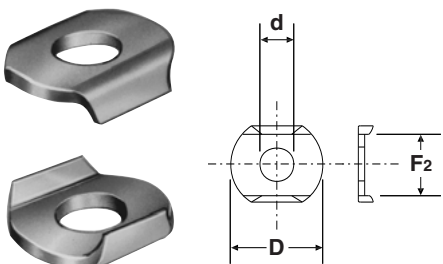

Part No.	ØD	Ød	F2	For Spindle Diameter
● 105906	[0.44] 11,2	[0.17] 4,3	[0.33] 8,3	M4 or #8
● 102911	[0.56] 14,2	[0.20] 5,1	[0.38] 9,6	M5 or #10
● 215905	[0.69] 17,5	[0.26] 6,7	[0.50] 12,7	M6 or 1/4
● 507907	[0.88] 22,4	[0.33] 8,4	[0.60] 15,2	M8 or 5/16
● 235906	[1.00] 25,4	[0.41] 10,5	[0.75] 19,1	M10 or 3/8
● 247909	[1.26] 32	[0.53] 13,5	[0.91] 23,2	M12 or 1/2
● 267902	[1.44] 36,6	[0.66] 16,8	[1.03] 26,2	M16 or 3/8

Preferred Market: ▲ NA/SA ■ Europe ● Global