

Series 424, 441 Product Overview

Features:

- Compact clamps with forged alloy steel construction for high strength
- Versions ending with (-2) are supplied with two adjustable spindles

Applications:

- Welding
- Assembly

Also Available:

See page 8.1 for accessories

424



424-2

With Two Adjustable Spindles



441



441-2

With Two Adjustable Spindles



Series 424, 441 Technical Information, Holding Capacities, Standard Clamp Dimensions

Model	Max. Holding Capacity	Weight	(K5) Maximum Clamping Thickness	Spindle (Supplied)
424	900 N [200 lbf]	0,14kg [0.31lb]	16 [0.63]	424208-M
424-2			7,4 [0.29]	(2X) 431208-M
441	1560 N [350 lbf]	0,29kg [0.63lb]	23,3 [1.03]	441203-M
441-2			20,8 [0.82]	(2X) 461203-M

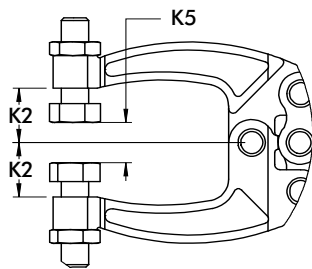

MODEL 424-2 & 441-2 AS SHOWN

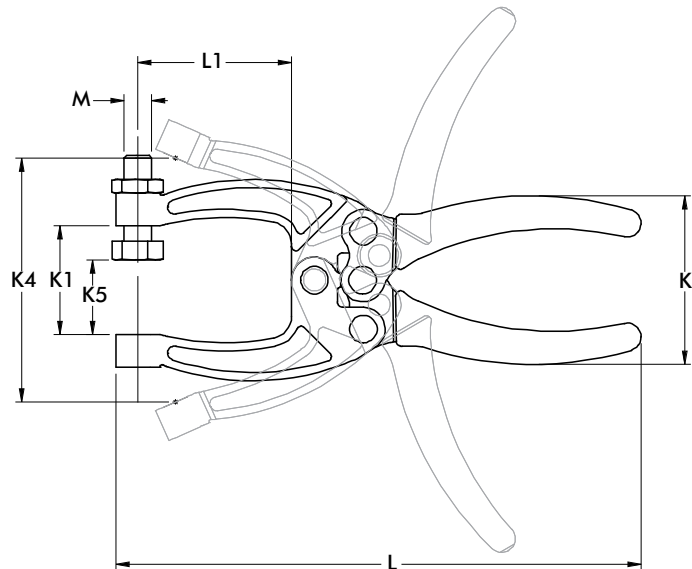
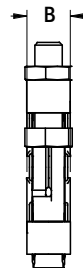

mm [INCH]
THIRD ANGLE PROJECTION

Model	B	K	K1	K2	K4	L	L1	M
424	[0.66]	[1.91]	[1.00]	[0.50]	[2.06]	[4.63]	[1.08]	M6
424-2	16.8	48.5	25.4	12.7	52.3	117.6	27.4	
441	[0.50]	[2.07]	[1.25]	[0.63]	[2.80]	[6.03]	[1.77]	M8
441-2	12.7	52.5	31.8	15.9	71.2	153.1	44.9	