

Series 317 Product Overview

Features:

- Dual mounting surfaces
- Large bar opening angle
- Accommodates M8 or 5/16" spindle accessories

Applications:

- Assembly & test
- Checking fixtures
- Light machining
- Woodworking

Also Available:

See page 8.1 for accessories
 817-U Pneumatic Toggle Clamp
 (See page 10.21)
 817-S Pneumatic Toggle Clamp
 (See page 10.21)



Note:
 Clamps shown with included accessories. To order without spindle, add (-LS) to the end of model (Ex: 317-U-LS)

Series 317 Technical Information

Model	Max. Holding Capacity	Clamp Bar Opening (+10°)	Handle Opening (+10°)	Weight	Accessories (Supplied)		
					Bolt Retainer	Spindle Assembly	Flanged Washers
317-U	1670 N [375 lbf]	185°	60°	0,34kg [0.75lbs]	---	507208-M	507107
317-S	1780 N [400 lbf]				207105	---	---

Series 317 Holding Capacities

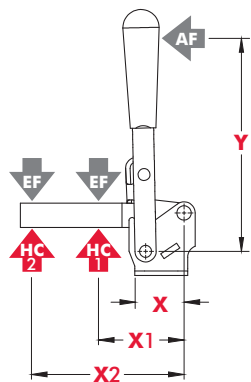

Model	X	X1	X2	Y	±HC1	±HC2	±EF(X1):AF	±EF(X2):AF
317-U	[1.57] 40,0	[2.00] 50,8	[3.75] 95,3	[4.00]	[375 lbf] 1670 N	[200lbf.] 900N	17:1	8:1
317-S		[2.50] 63,5	[5.00] 127,0	101,6	[400 lbf] 1780 N	[190lbf.] 850N	13:1	5:1

Dimensions shown "mm [inch]" ± HC = Holding Capacity, EF = Exerting Force, AF = Applied Force
 Refer to page 20.5 for additional information.

Series 317 Standard Clamp Dimensions
-U/-S

317-U
U-Bar

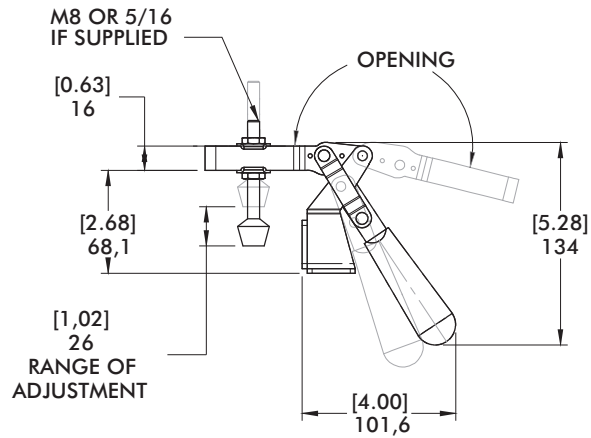
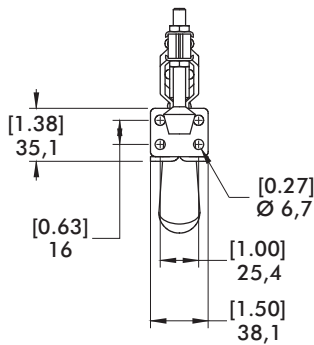
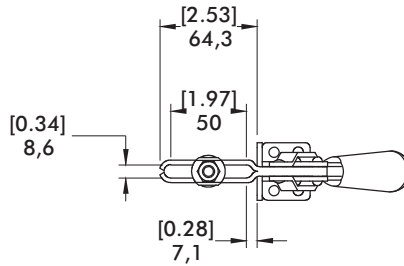
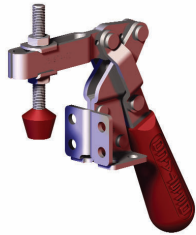

317-S
Solid Bar

